

CHANGESPEED BOX

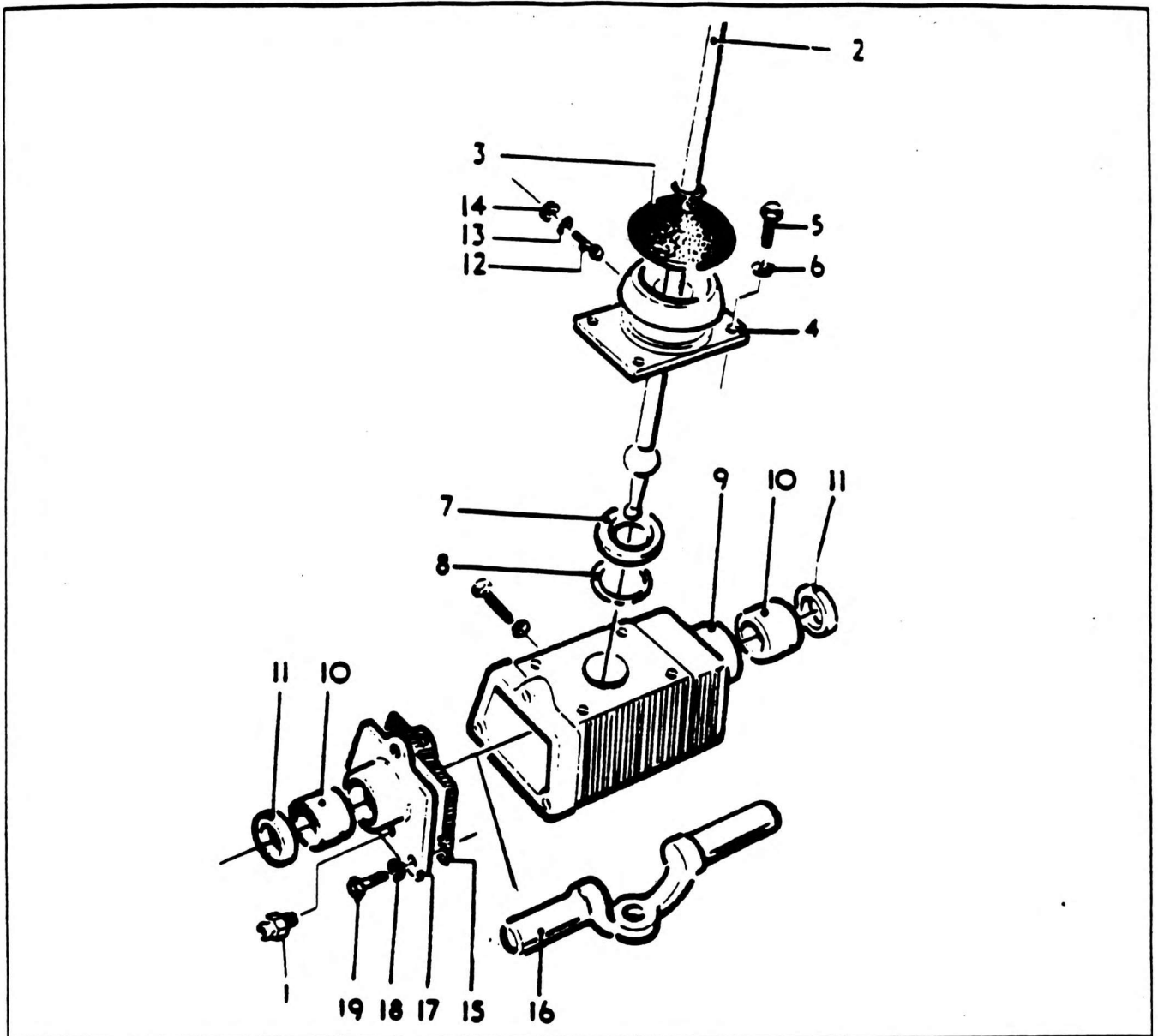

NO	PART NO	QTY	DESCRIPTION	NO.	PART NO.	QTY	DESCRIPTION
-	6-593-990266	1	Complete Assembly	17	9-352-100026	1	Cap Housing
1	9-352-100028	1	Grese Nipple	18	9-904-101861	3	Washer
2	§	1	Lever	19	9-352-100022	3	Capscrew
3	9-352-100032	1	Boot Lever				
4	9-352-100023	1	Tower Change Control				
5	9-904-101813	4	Capscrew				
6	7067206	4	Washer Spring				
7	9-352-100024	1	Seat Ring				
8	9-352-100025	1	Washer				
9	9-352-100035	1	Housing				
10	9-352-100027	2	Bush Housing				
11	9-352-100004	2	Oil Seal				
12	9-904-101860	1	Pin Lever Pivot				
13	9-904-101861	1	Washer Plain				
14	7064002	1	Nut Hexagonal				
15	9-352-100029	1	Gasket End Cap				
16	9-352-100031	1	Yoke Shifting				

§ For part number of item 2 refer to drawing 6-593-990266.